



Concrete Crack Data Logger, Wifi

This manual has been designed by the manufacturer to provide the necessary information regarding the instrument HC-2956 to those who are authorized to safely carry out its installation, maintenance, dismantling and disposal. All the necessary information for buyers and planners can be found in the sales catalog. Other than adopting good technical construction methods, the information should be read carefully and strictly applied. Observance of this information could cause risks for the health and safety of people and economical damage. This information, has been provided by the manufacturer in the original language (Italian), and is also available in other languages to satisfy legislative and/or commercial needs. This manual must be kept in good condition by a responsible person in an ideal place so that it is always available for consultation. In case this manual is lost or deteriorates, a replacement should be requested or downloaded from the Humboldt website. This manual reflects the state of skill of the instrument at the time of input on the market: however the manufacturer reserves the right to make changes, add or improve the manual without giving any reason to hold the present manual inadequate.

Environmental conditions

Temperature setting: min. 0°C, max. + 50°C.

It is forbidden to use this instrument in any other than its specific use and not in potentially explosive conditions or where anti-explosive elements are used.

Storage

Below are some references to be followed for the storage of the instrument. Avoid environments with excessive humidity and those exposed to bad weather (avoid open areas). Avoid putting the instrument directly on the ground. Store the instrument in its original packing.

Conformity declaration and EC marking

The instrument answers to the following Communitarian Directives: 2004/108/EC Electromagnetic compatibility, with reference to general Rules EN61000-6-2 (immunity in industrial environment) and EN 61000-6-3 (emission in residential environment).

Maintenance

The instrument does not need a particular maintenance except cleaning to do only with a soft cloth dampen with ethylic alcohol or water. Do not use hydrocarbon solvents (petrol, diluants, etc.): the using of these products could affect the proper functioning of the instrument. Repairs should only be attempted by Humboldt and the original manufacturer.

Calibration and Tests

It is advisable to calibrate the instrument periodically, once every working year. To do the calibration, follow the calibration procedure indicated in the present manual.

Assistance request procedure

For any kind of technical assistance request, contact the sales department of the Manufacturer directly indicating the information given on the identification plate, the number of hours used and the type of defect.

Manufacturer's responsibility

The manufacturer declines any responsibility in case of: Using the instrument contrary to the national safety and accident-prevention laws.

Wrong installation, in observance or wrong procedures of the instructions provided in the present manual.

Defective electrical power supply.

Modifications or tampering

Operations carried out by untrained or unqualified staff.

The safety of the instrument also depends on the strict observance of the procedures indicated in the manual: always operate the instrument in its functioning capacity and carry out a careful routine maintenance.

All phases of inspection and maintenance should be done by qualified staff.

The configurations provided in the manual are the only ones permitted.

Do not try to use it anyway contrary to the indications provided.

The instructions in this manual do not substitute but accomplish the obligations of the current legislation regarding the safety laws.

Description

Crack meter with integrated datalogger having independent operation which is used to monitor cracks, joints and linear displacements by recording displacement and ambient temperature values. Based on a rotary precision potentiometer which is driven by the winding/unwinding of a stainless steel wire. The key characteristics of the crack meter are low cost, simple installation, minimized visual impact. Ideal for the evaluation and control of cracks, joints, and for the measurement of linear displacements in general. Stroke 80mm. Powered by an internal battery. Wireless connection to a PC with a specific USB wireless communication module for set-up and export of measurement data.

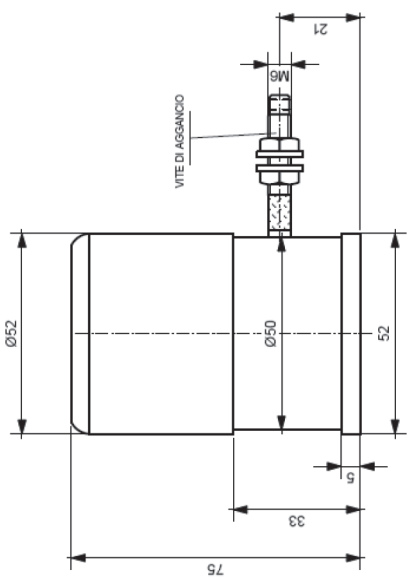
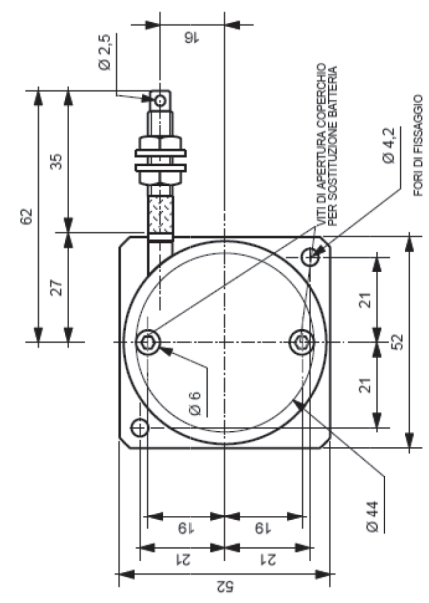

Installation

The device must be installed on a flat surface. Fix the instrument housing on one side of the crack to monitor and the head of the wire on the other side. The wire must have a normal (90°) orientation to the crack. Position the housing at a higher elevation than the head of the wire. The two holes in the bottom of the housing allow an easy and direct installation to the surface. The stainless steel wire must be anchored using the M6 threaded screw or using the hole at its extremity. Avoid bends and distortions of the wire.

Do not exceed the maximum stroke. During installation operations do not abruptly release the drawn wire, which must rewind slowly and never snap back into the housing. Always gently accompany the head of the wire until completely it is completely rewound. Protect the instrument from excessive temperatures and when installed externally do not expose it to direct sunlight.

Power supply

The device is powered by a ½ AA 3.6V battery that has a lifetime which depends upon the number of acquisitions and number of data download: for example, with 1 acquisition per hour and 1 download per month, the battery lasts approximately 6 months. If the battery is depleted before data transfer is complete, it is sufficient to substitute it and execute normally the download operation. In any case the recorded data is maintained even if the battery is depleted.

PC connection

Management, configuration, and download of the data is done through the Windows PC software using the USB wireless module.

Technical characteristics

Displacement sensor: Precision potentiometer Measurement range : 80 mm
Resolution: 0,003 mm Linearity: 0,07% full scale

Temperature sensor: Measurement range: -20° +80°C Resolution 1°C

Datalogger: A/D conversion: 15 bit memory: EEPROM data security: CRC redundant capacity: 31926 readings or 15963 readings with redundant recording acquisition interval: 1min to 5 years

Interface: External connection: wireless 868 MHz. Hardware interface: USB wireless module Software interface: programming and interface with Windows software

Power supply: ½ AA 3.6 Volt battery typical lifetime: 6 years

Range: 150 m in free space

Working temperature: -55° to +85°C or according to the battery specs

Wire tension: 10N

Protection rating: IP65

Mass: 200gr **Housing:** Anodized aluminum and transparent ABS

Electromagnetic compatibility: 2004/108/CE

Warranty

Humboldt Mfg. Co. warrants its products to be free from defects in material or workmanship. The exclusive remedy for this warranty is Humboldt Mfg. Co., factory replacement of any part or parts of such product, for the warranty of this product please refer to Humboldt Mfg. Co. catalog on Terms and Conditions of Sale. The purchaser is responsible for the transportation charges. Humboldt Mfg. Co. shall not be responsible under this warranty if the goods have been improperly maintained, installed, operated or the goods have been altered or modified so as to adversely affect the operation, use performance or durability or so as to change their intended use. The Humboldt Mfg. Co. liability under the warranty contained in this clause is limited to the repair or replacement of defective goods and making good, defective workmanship.

Humboldt Mfg. Co.

875 Tollgate Road
Elgin, Illinois 60123 U.S.A.

U.S.A. Toll Free: 1.800.544.7220

Voice: 1.708.456.6300

Fax: 1.708.456.0137

Email: hmc@humboldtmfg.com

Testing Equipment for



Construction Materials

HUMBOLDT

www.humboldtmfg.com