



H-1240 & H-1240.4F



Electric
Penetrometer
with Digital
Automatic Timer

Introduction

The Humboldt Electric Automatic Penetrometer is of rugged construction, but requires careful handling to safeguard its accuracy. Keep the instrument clean at all times – especially the drop and indicator plungers, which constitute the spindle assembly. Use denatured alcohol as the cleaner for these surfaces.

For complete test procedure(s), refer to the following specifications: ASTM D5, D217, D937, D1168, D1321, D1403, D1831, and AASHTO T49.

Installation

1. Level the instrument carefully by means of the leveling screws on the base, sighting the spirit level from above, in order to obtain accurate alignment. After the instrument has been leveled, avoid shifting its location.
2. Position the height of the supporting casting by turning the knurled travel nut on the main support post and then tighten the black knob.
3. If additional weights are used, these should be taken from the side post and set on the end of the plunger (opposite end of the needle chuck).
4. Insert penetrating needle or cone into chuck and tighten the chuck screw.

Instruction

As supplied by Humboldt the unit is programmed to provide a solenoid actuation period (plunger release) of 5 seconds. The panel-mounted, electronic timer uses 120 VAC, 50/60 Hz. In order to use 240 VAC, a step-down transformer or converter suitable for digital circuits is required. The H-1240.4F is supplied with an H-1042 transformer for this purpose and is plug compatible with the penetrometer cap-plug, but requires the input line cord to the transformer to be wired for local service.

For further timer information refer to the ATC Model 365B Long Range Timer Instructions.

Operation

1. Holding the plunger with one hand, squeeze the lever on the front of the support casting with the other to allow raising the plunger & needle to clear the sample. Flip the toggle switch on the front panel to the up position and pre-select the specified time of penetration by turning the knobs on the timer bezel.
2. To conduct a test set the needle, cone or micro-cone on the sample surface. When ready to begin, press the red pushbutton on the front panel to release the plunger for the pre-selected amount time. The timer-controlled electromagnet will immediately release the plunger and after the preselected time interval will re-grip it to stop the test.
3. Measure the travel of the plunger assembly by lowering the dial indicator rod to contact the plunger and observing the dial reading.

4. To reset for the next test, the front panel toggle switch must first be flipped to the down position, then the above sequence can be repeated.

CAUTION: Keep hands, clothing and other objects away from moving parts when the machine is in operation.

Drawing

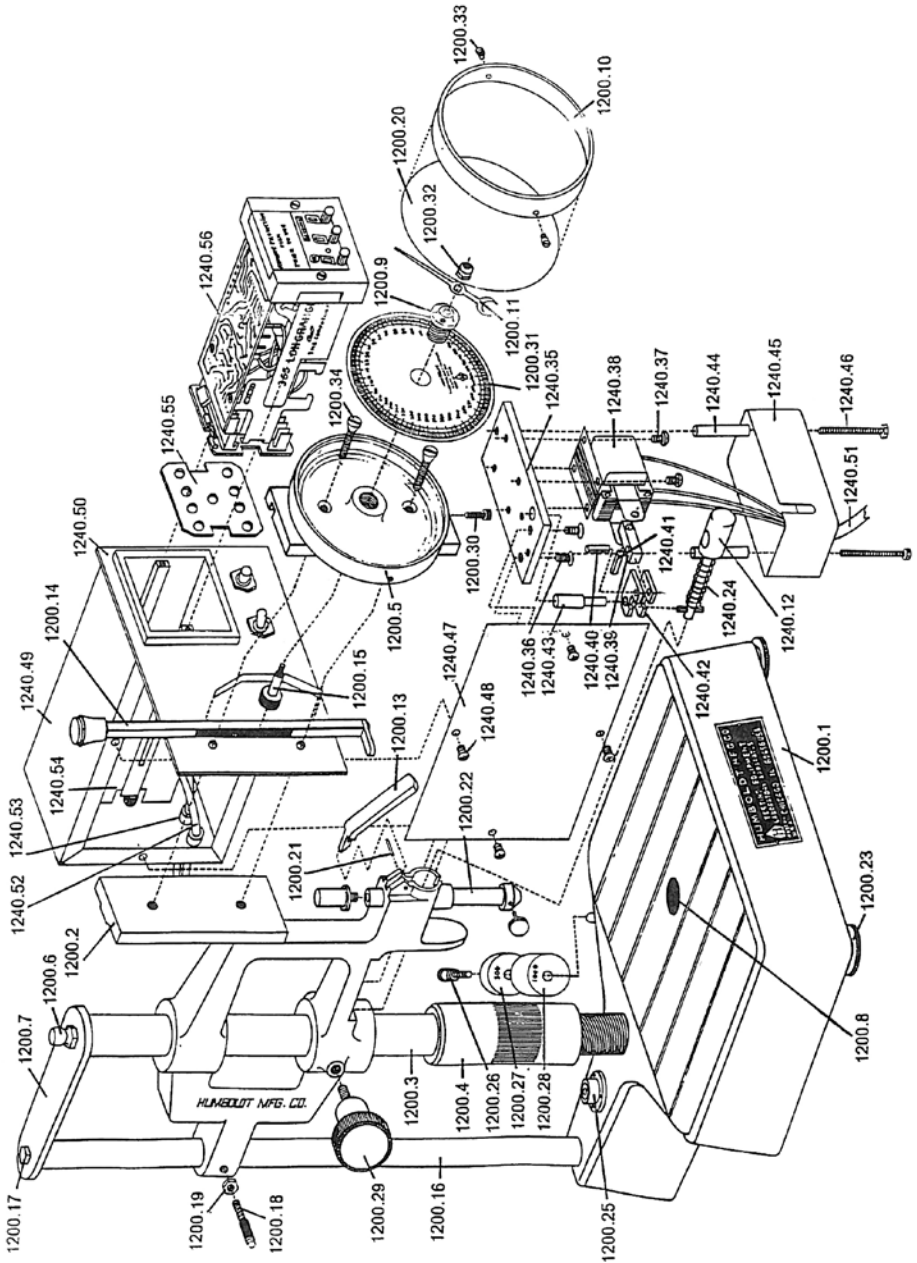

H-1240

Penetration Needles and Cones

Application	Specification	Model	Description
Bituminous materials	ASTM D5; AASHTO T49, IP49; ASA Std., A37.1; Fed Spec. SS.R. 406C, Meth. 214.01	H-1280	Standard hardened stainless steel needle, 40-45mm exposed needle length. Wt. 2.5g.
		H-1300	Same as H-1280. Certified to ASTM accuracy by independent laboratory. Wt. 2.5g.
		H-1302	Same as H-1290. Certified to ASTM accuracy by independent laboratory. Wt. 2.5g.
		H-1290	Long hardened stainless steel needle, 50-55mm exposed needle length. Wt. 2.5g.
Waxes with 250 or less penetration	ASTM D1321	H-1310	Hardened stainless steel wax penetration needles with tapered point, blunt tip of truncated cone. Ferrule is approx. 3.2mm dia. Wt. 2.5g.
		H-1317	Same as H-1310. Certified to ASTM accuracy by independent laboratory.
Battery paste	N/A	H-1255	Hardened stainless steel tip with special plunger. Total wt. 60g ± .050g.
Joint sealant for asphalt & concrete pavements	ASTM D5329	H-1320	Resilience ball penetration tool. Total wt. 27.5g.
Grease-testing penetrometers	ASTM D217, D937 ASA Std. Z11.3	H-2520	Hollow 90° brass cone, highly polished stainless steel tip. Removable nut and stem. Wt. 102.5g.
		H-2522	Same as H-2520, completely made of stainless steel. Wt. 102.5g.
For all 90° cones		H-2525	Stainless steel replacement tip, nut and stem.
Grease-testing penetrometers	ASTM D2884	H-2524	Magnesium cone and plunger, same dim. as H-2520. Total wt. cone and plunger 30.0g.
Food products and paste paints	U.S. Dept. of Agriculture	H-2529	Aluminum. Same dimension as H-2520. Total wt. 35g.
(shortenings, margarine, butter, etc.) Measuring firmness of solid and plasticized fats	AOCS Cc 16-60	H-1270	10° aluminum cone, 3.2mm ferrule, 0.8mm stainless steel blunt tip. Overall length 106mm. Wt. 45g.
(i.e., recovery of used grease) Small obtainable samples	ASTM D1403	H-2519	1/4 scale. (Not considered a substitute for full-size cone specified in ASTM D217.) Wt. 9.38g.

Penetration Needles and Cones



H-1280
H-1290
H-1300
H-1302



H-1310
H-1317



H-1255



H-1320



H-1270



H-2519



H-2520
H-2522
H-2529

Warranty

Humboldt Mfg. Co. warrants its products to be free from defects in material or workmanship. The exclusive remedy for this warranty is Humboldt Mfg. Co., factory replacement of any part or parts of such product, for the warranty of this product please refer to Humboldt Mfg. Co. catalog on Terms and Conditions of Sale. The purchaser is responsible for the transportation charges. Humboldt Mfg. Co. shall not be responsible under this warranty if the goods have been improperly maintained, installed, operated or the goods have been altered or modified so as to adversely affect the operation, use performance or durability or so as to change their intended use. The Humboldt Mfg. Co. liability under the warranty contained in this clause is limited to the repair or replacement of defective goods and making good, defective workmanship.

Humboldt Mfg. Co.

3801 North 25th Avenue
Schiller Park, Illinois 60176 U.S.A.

U.S.A. Toll Free: 1.800.544.7220

Voice: 1.708.456.6300

Fax: 1.708.456.0137

Email: hmc@humboldtmgf.com

Testing Equipment for



Construction Materials

HUMBOLDT

www.humboldtmgf.com