



Large-Capacity
Vacuum Pycnometer

General

The Large-Capacity Vacuum Pycnometer unit has many of the same features as H-1750 but also has sample capacity of 10L (2.64 gal.), 6kg (13 lbs.) weight, with maximum aggregate size of 50mm (2 inches). Set features domed transparent cover for easy observation of sample testing. Unit includes water inlet valve and ¼" I.D. hose, quick disconnect, vacuum gauge, vacuum hose and aspirator with 3/8" NPT fitting. Flange O.D. is 10-3/4" (273mm); maximum clearance above plate is 7-3/4" (197mm). Order H-1826A or H-1826A.5F vibrating table, vacuum pump and H-1752, H-1754 or H-1754D manometer separately. Replacement parts are available separately. Dimensions: 9-7/16" I.D. x 12-1/8" (240 I.D. x 311mm). Meets ASTM D2041; AASHTO T209, T283.

Shipping Inspection

Your Humboldt Vacuum Pycnometer was inspected and tested prior to shipping. Carefully check the instruments and accessories for any damage, which may have occurred in transit. Claims for any damage must be made against the delivering carrier, but Humboldt should also be notified so that we can assist you as much as possible.

Specifications

Sample size: Up to 10 liters
Reproducibility: Better than 0.4%
Dimensions: 16"H x 10 ¾" OD

Operating Procedure

1. Weigh and record weight of empty Vacuum Pycnometer.
2. Load the sample into the Vacuum Pycnometer.
3. Weigh the Vacuum Pycnometer containing the sample to be tested. Calculate and record the initial weight of the sample.
4. Connect the aspirator to a water faucet and to the Vacuum Pycnometer.
5. Connect the water inlet hose to the water supply and the Vacuum Pycnometer.
6. Operate the aspirator by turning on the faucet to which it is attached to create a vacuum of at least 10" of HG within the sample chamber.
7. Open the water inlet valve and allow the Vacuum Pycnometer to fill completely, being careful not to turn off the aspirator.
8. Close the water inlet valve.
9. Disconnect the aspirator and the vacuum gauge at the quick-disconnects from the Vacuum Pycnometer.
10. If the Pycnometer is not full, use the squeeze bottle to fill with water.
11. Disconnect the water inlet hose and the quick-disconnect from the Vacuum Pycnometer.
12. Weigh the Vacuum Pycnometer and record the final weight.

Calculations (From ASTM D2041-00, Section 10)

If the test temperature is within 72°F and 80°F, Equation 1, maybe used to calculate specific gravity within 0.001 points or less error due to the thermal effects.

$$\text{SP. GR.} = \frac{A}{A+D-E} \quad \text{Equation 1}$$

Where:

A = Mass of dry sample in air, G

D = Mass of container filled with water at 77°F, G

E = Mass of container filled with water and sample at 77°F

If the test temperature differs significantly from 77°F, correct for thermal effects as follows:

$$\text{SP. GR.} = \frac{A}{(A+F)-(G+H)} \times \frac{DW}{0.9970} \quad \text{Equation 2}$$

Where:

A = Mass of dry sample in air, G

F = Mass of Pycnometer filled with water at test temperature, G

G = Mass of Pycnometer filled with water and sample at test temperature, G

H = Correction for thermal expansion of bitumen, G

DW = Density of water at test temperature, MG/M3

0.9970 = Density of water at 77°F. MG/M3

For details see ASTM D2041-00, Section 10

Troubleshooting

- Pycnometer not getting vacuum:
 1. Check "o-ring" to make sure it is clean and in good shape. If not, get a replacement "o-ring" from your distributor.
 2. Check to make sure the water inlet valve is on tight.
 3. Tighten the stopcock nut (at the bottom of stopcock) of the water inlet valve.
- Air bubbles entering from the Water Inlet Valve:
 1. Follow the procedure of 2 and 3 above.
- Clogged in-line filter
 1. Replace the filter assembly.
- Too many air bubbles in water.

Air bubbles come from dissolved in water. You can check for this by opening water inlet valve (keeping the water inlet hose connected to the water supply) after you have gone through step 8 of the operating procedure. The air bubbles should dissolved back in water at atmospheric pressure.

Try filling the pycnometer with boiled water (after it has been cooled).

IF PROBLEM STILL PERSISTS, CONTACT HUMBOLDT MFG. COMPANY FOR ASSISTANCE.

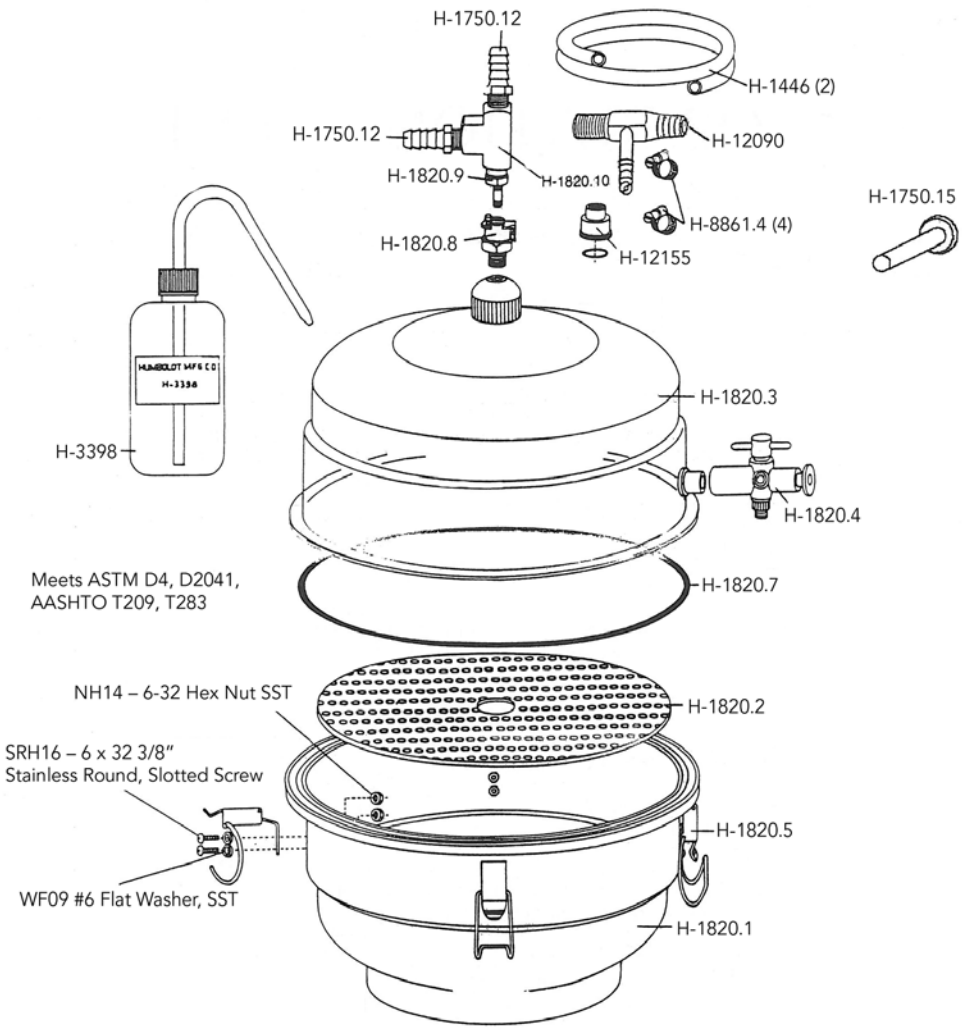

H-1820

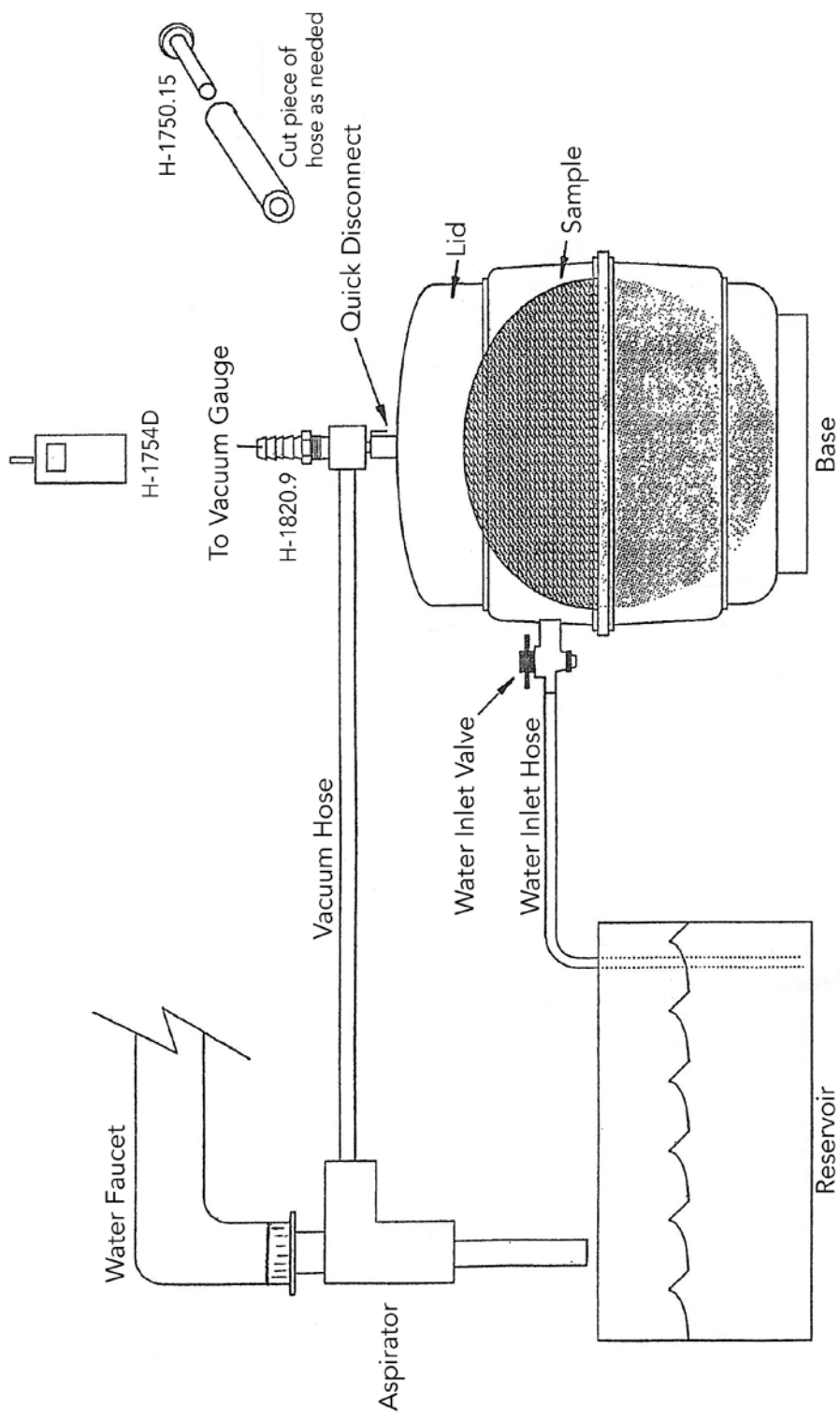

Warranty

Humboldt Mfg. Co. warrants its products to be free from defects in material or workmanship. The exclusive remedy for this warranty is Humboldt Mfg. Co., factory replacement of any part or parts of such product, for the warranty of this product please refer to Humboldt Mfg. Co. catalog on Terms and Conditions of Sale. The purchaser is responsible for the transportation charges. Humboldt Mfg. Co. shall not be responsible under this warranty if the goods have been improperly maintained, installed, operated or the goods have been altered or modified so as to adversely affect the operation, use performance or durability or so as to change their intended use. The Humboldt Mfg. Co. liability under the warranty contained in this clause is limited to the repair or replacement of defective goods and making good, defective workmanship.

Humboldt Mfg. Co.

3801 North 25th Avenue
Schiller Park, Illinois 60176 U.S.A.

U.S.A. Toll Free: 1.800.544.7220

Voice: 1.708.456.6300

Fax: 1.708.456.0137

Email: hmc@humboldtmfg.com

Testing Equipment for



Construction Materials

HUMBOLDT

www.humboldtmfg.com