



**HUMBOLDT**

**H-2790, H-2791 & H-2792**

**Instruction Manual**

**HI-LOW DETECTOR**

*Manufactured by:*

**Humboldt Mfg. Co.**

7300 West Agatite Avenue  
Norridge, Illinois 60706 U.S.A.

*Customer Service:*

Tel: 1.708.456.6300

Fax: 1.708.456.5412

Email: [hmc@ehumboldt.com](mailto:hmc@ehumboldt.com)

USA Toll Free: 1.800.544.7220

Website: [www.humboldtmfg.com](http://www.humboldtmfg.com)

*Sold and Serviced by:*

**Humboldt and Authorized Dealers Worldwide**

## **TABLE OF CONTENTS**

	Page
1. General Information .....	3
2. Assembly .....	3
3. Components .....	3
4. Adjusting & Checking Accuracy .....	4
5. Specification .....	5
6. Accessories/Replacement Parts .....	5
7. Maintenance .....	5
8. Warranty .....	6
9. Drawing .....	6

## 1. General Information

The Hi-Low Detector is a device used for detecting and marking the points on a roadway surface that deviates from the desired level of grade. It is a precision-made straightedge, for checking both concrete and blacktop slabs. Basically, the machine consists of an I-beam body 10 to 16 feet long with riding wheels at the ends and a detector wheel at the middle, so that the machine can be steered on the surface. The detector wheel, located at the middle of the machine, detects any vertical deviation of the surface from a straight line between the supporting wheels at the ends of the machine.

The vertical deviations are shown by a movable pointer over a visible scale. Markings can be made on the surface using a special dye kept in a reservoir and release valve control mechanism. The timing and location of the marking can be controlled through a cable at the operator's handle.

The Hi-Low Detector is shipped completely assembled except for attaching the operator's handle, rear steering rod, and dye release cable.

## 2. Assembly

- 2.1 Attached the handle and steering rod to the I-beam body.
- 2.2 Run the loose end of the dye marker cable through the guide bracket so that 7/16" (11mm) of cable wire extends beyond the bracket.
- 2.3 After tightening the bracket, adjust the push collar on the end of the cable wire so that it clears the control valve lever by 1/32" (0.8mm).
- 2.4 With this setting, the push collar should fully open the control valve when the dye release lever on the handle is actuated.
- 2.5 Connect the rear steering rod to the front wheel assembly. This will enable the front wheels to turn about 20° to the right or left.

## 3. Components

- 3.1 **Front Wheel Lock:** The front wheel can be locked in a straightforward position by turning the spring actuated locking rod off the holding peg. With this rod in the down or locked position, the front wheel is non-steerable as required when the Hi-Low Detector is used for aligning forms.
- 3.2 **Tire Scrapers:** An adjustable tire scraper is mounted in front of each wheel and preset to clear the wheel by approximately 1/32" (0.8mm). These scrapers prevent mud and dirt from accumulating on the rubber-tired wheel, which would result in inaccurate readings. After long periods of use, it may be necessary to reset these tire scrapers to 1/32" (0.8mm) clearance on each wheel.

- 3.3 **Aerosol-Spray Dye Marking System:** Irregular surfaces are marked by aerosol-spray dye. Upon receiving the visual indicator signals, the operator depresses a button on the steering handle that controls the marking-dye discharge valve. Bright orange dye sprays onto the irregular surface from a replaceable aerosol can that is mounted directly beside the indicator wheel. A series of long, parallel dye streaks laid down by repeated passes on the uneven area vividly marks high and low spots for correction. Use of the non-clogging aerosol can for dye discharge eliminates mixing, permits precision marking, and prevents waste.

#### 4. Adjusting & Checking Accuracy

- 4.1 Quickly check for accuracy by hooking the spring-loaded line underneath the wheels as shown in Figure 1.
- 4.2 To set the indicator wheel exactly on the line, loosen the wing nut at point "A" and turn screw "A" upward until the wheel is right on the line. With the wheel in this position, the indicator needle should read zero. If it does not, release lock nut "B" and turn rod at "C" up or down until a zero reading is obtained. Then tighten nut "B" and back off or lower screw "A" until the arm rests on lower stop "D".

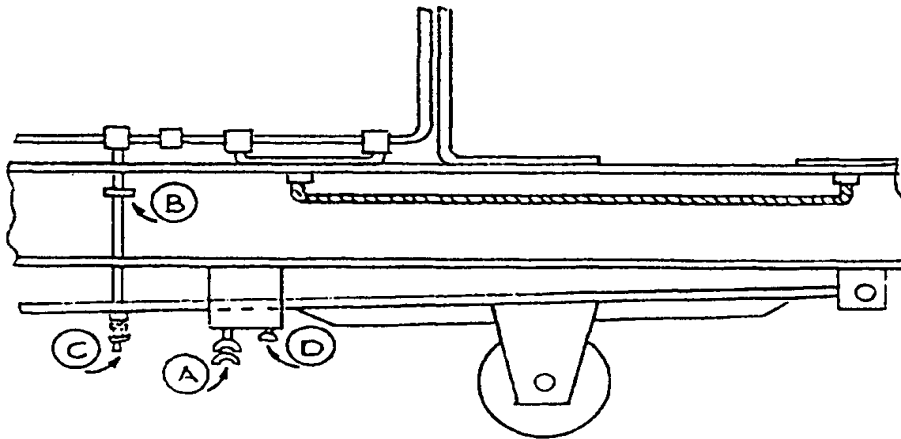

Figure 1

- 4.3 The Hi-Low Detector can be quickly checked for accuracy without using the storage and transport frame by lowering the front and rear wheel guides. This raises the wheels off of the ground so that the spring-loaded line can be stretched underneath.

---

## 5. Specification

Frame	Rectangular aluminum stock
Stands	Front and rear; for storage, transport, and testing
Wheels	Ground concentric with inside diameter of their ball bearings; neoprene tires and adjustable scraper blades for accuracy; one front, one rear and one center indicator wheel
Dye	Bright orange; 12 oz. (340g) aerosol can; mounts beside indicator wheel; contains no fluorocarbons; non-clogging
Handle	For steering; with button for discharging dye
Scale	Vertical; large pointer; mounted above indicator wheel; magnifies variations 16X
Gradations	1mm
Readings	Magnified; range from 0 to 1/4" (6.4mm), high or low
Weights	H-2790: Net 70 lbs. (32kg); Shipping 140 lbs. (64kg) H-2791: Net 80 lbs. (36kg); Shipping 160 lbs. (73kg) H-2792: Net 102 lbs. (46kg); Shipping 200 lbs. (91kg)

## 6. Accessories/Replacement Parts

H-2790B	Bell/Buzzer indicator SYSTEM. Powered by a 6-volt battery
H-2790D	Replacement aerosol dye. Carton of 12, 12 oz. (340g) spray cans.

## 7. Maintenance

With normal use and handling, this machine will perform accurately over long periods of time and needs only occasional rechecking for accuracy.

## 8. Warranty

Humboldt Mfg. Co. warrants its products to be free from defects in material or workmanship. The exclusive remedy for this warranty is Humboldt Mfg. Co., factory replacement of any part or parts of such product, for the warranty of this product please refer to Humboldt Mfg. Co. catalog on Terms and Conditions of Sale. The purchaser is responsible for the transportation charges. Humboldt Mfg. Co. shall not be responsible under this warranty if the goods have been improperly maintained, installed, operated or the goods have been altered or modified so as to adversely affect the operation, use performance or durability or so as to change their intended use. The Humboldt Mfg. Co. liability under the warranty contained in this clause is limited to the repair or replacement of defective goods and making good, defective workmanship.

**CAUTION:** Keep hands, clothing and other objects away from moving parts when the machine is in operation.

## 9. Drawing

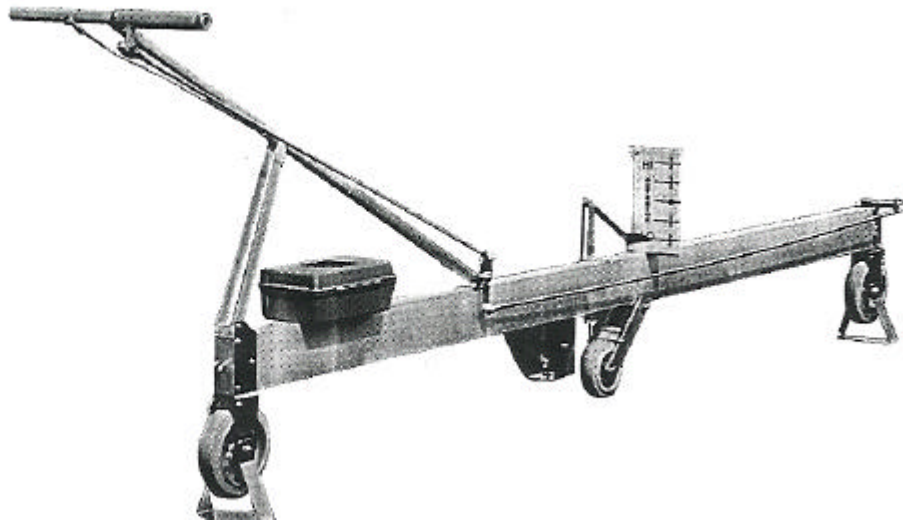

**H-2790, H-2791 & H-2792**