



H-1334B & H-1334BA



Automatic Counter
For Marshall Compactors

General

The H-1334B and H-1334BA are automatic counters with a 6-digit LCD readout designed for use with the following Humboldt Marshall Compactors:

H-1334B: H-1336, H-1346, H-1356

H-1334BA H-1364, H-1366

These counters feature a non-contact sensor to record a settable number of hammer blows. The counters automatically shut-off the compactor when the preset number of blows is reached. In use, these counters should be isolated from the compactor and not mounted directly to it, to avoid vibration damage. Also refer to the manual for your Marshall compactor, for how to use these counters.

Operating Instructions

1. The diagram on the page 4 shows the two 6-32 screw holes "A" in the center crossbar marked "B".
2. The steel angle bracket marked "C" is mounted to the center crossbar "B" via the two 6-32 screws provided.
3. The proximity sensor switch "D" is inserted through the large hole in the bracket with a nut "E" on either side of the leg.
4. Lift the compactor hammer weight by hand. The hammer weight should pass approximately 1/2" from the end of the proximity switch.
5. Make sure both the 6-32 "A" screws and the proximity switch nuts "E" are securely locked into place.
6. We recommend that the control box be mounted on the wall behind the compactor or on an adjacent table.
7. Plug the power cord from the compactor into the back of the counter "H" and the power cord from the counter into a power socket (115V, 50/60Hz for H-1334B and 220V, 50/60 Hz for H-1334B.4F).
8. After all the cords are plugged into their respective sockets, switch the toggle switch "F" to the "ON" position, the display "I" should indicate "0" in the upper and lower rows. Use selector switches "G" to set the predetermining counter to the desired number of blows, which will appear in the lower display.
9. To begin a count cycle, push the black button "J". If the upper display indicates a value less than the preset count, it activates the motor.
10. The upper display will increment up to the preset count, one count each time the sensor input pulses the counter.
11. When the upper display indicates "the preset value", the motor will stop.
12. To begin another count cycle for the same preset, push the black button. Otherwise, change the preset as noted in step 8 and then press the black button.

CAUTION: Keep hands, clothing and other objects away from moving parts when the machine is in operation.

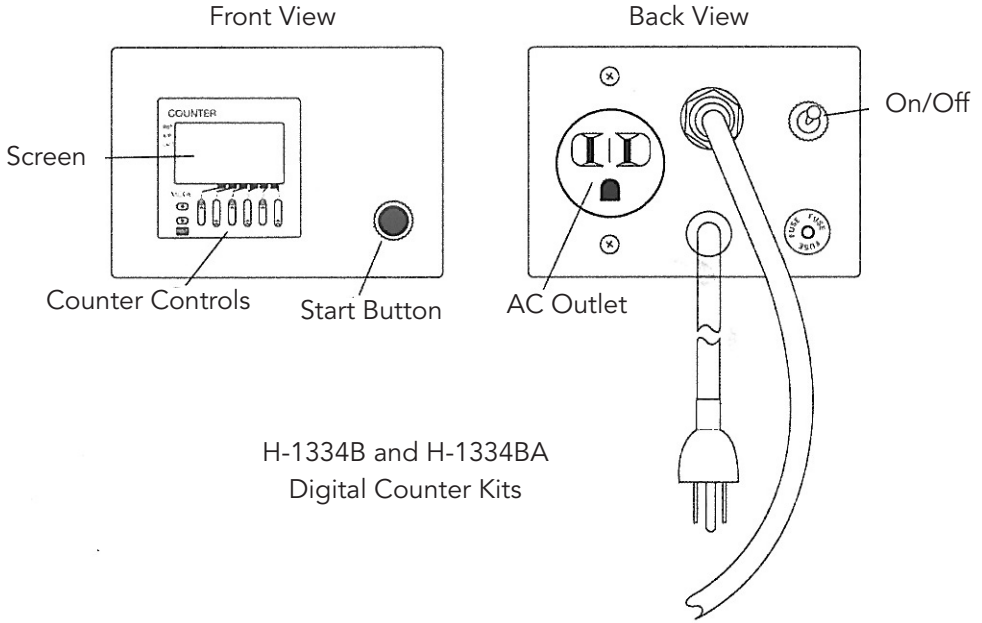

H-1334B — Installing the Proximity Sensor for your H-1334B Automatic Counter on a Humboldt H-1336D, H-1346D and H-1356D Marshall Compactor.

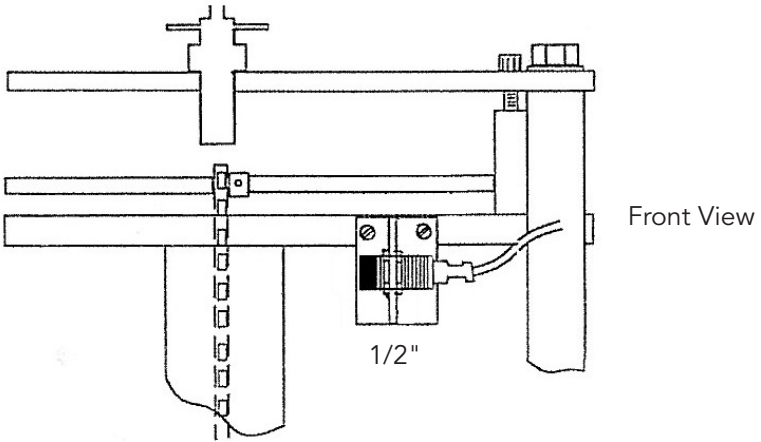
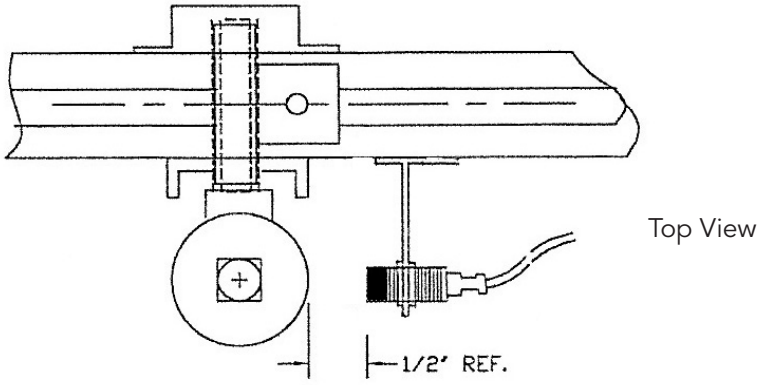

H-1334BA — Installing the Proximity Sensor for your H-1334BA Automatic Counter on a Humboldt H-1364, H-1366 Marshall Compactor.

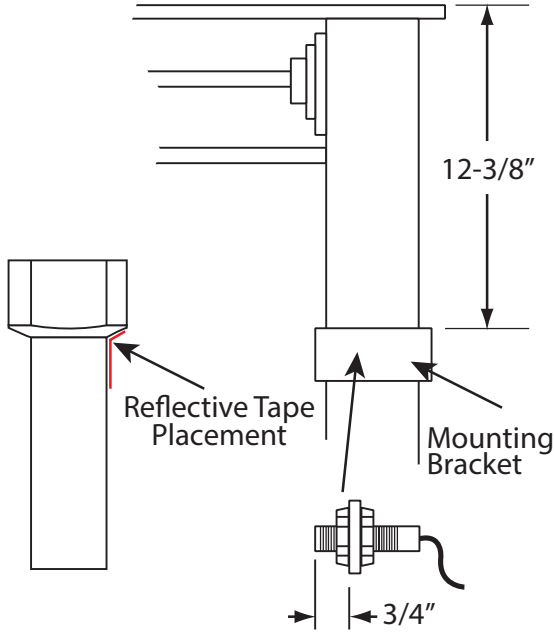

From the front, observe the clamping plates clamped by a hand knob to the right side beam. The retro-reflective, infra-red sensor is mounted in front and secured with two nuts, one on each side.

The Sensor is positioned, as shown in the diagram above, with the indicating light facing forward. When the sensor receives a signal from the reflective tape target, the light will flash and send a signal to the counter. It may be necessary to adjust the sensor range if you are experiencing counting problems (missed counts/no counts). To adjust the sensor, use the screw on the back of the sensor to adjust the retroreflective infrared beam to achieve consistent counting actuation is achieved.

When the hammer is lifted and sensed by the photo eye, then dropped out of view, a count is registered. Use of the reflective tape enclosed (see diagram), may be necessary (depending on the hammer finish) to ensure only one transition per drop is registered.

After testing indicates it is necessary to adjust the height of the sensor, position the sensor by loosening the hand knob holding the clamping plates and sliding the assembly into position.

Warranty

Humboldt Mfg. Co. warrants its products to be free from defects in material or workmanship. The exclusive remedy for this warranty is Humboldt Mfg. Co., factory replacement of any part or parts of such product, for the warranty of this product please refer to Humboldt Mfg. Co. catalog on Terms and Conditions of Sale. The purchaser is responsible for the transportation charges. Humboldt Mfg. Co. shall not be responsible under this warranty if the goods have been improperly maintained, installed, operated or the goods have been altered or modified so as to adversely affect the operation, use performance or durability or so as to change their intended use. The Humboldt Mfg. Co. liability under the warranty contained in this clause is limited to the repair or replacement of defective goods and making good, defective workmanship.

Humboldt Mfg. Co.

3801 North 25th Avenue
Schiller Park, Illinois 60176 U.S.A.

U.S.A. Toll Free: 1.800.544.7220

Voice: 1.708.456.6300

Fax: 1.708.456.0137

Email: hmc@humboldtmfg.com

Testing Equipment for



Construction Materials

HUMBOLDT

www.humboldtmfg.com