



Marshall,
Automatic,
Single Compactor

Introduction

The Humboldt Automatic Marshall Compaction Machine is designed to provide a stable and rigid mechanism for producing 4" or 6" diameter asphalt pills used in Marshall tests. The heavy-duty design stands up well to the constant jarring caused by the compaction process. The H-1364R and H-1366R feature a rotating mold mechanism and a hammer with a beveled foot, which together produce a kneading action when producing test pills. The machine's automatic counter allows the operator to preset the number of blows wanted and will turn off the machine when completed. After the number of blows has been set, the operator can start the machine with a push button and keep track of the number of blows on an LED readout. The counter can be operated on either 115V/60Hz or 230V/50Hz, switchable inside the cover. A cam-action lever operates the integral mold holder to facilitate insertion and removal of the stability mold. The H-1364 and H-1366 models are identical to the machines above except these have a stationary mold (non-rotating) and use a flat bottom hammer.

Machines can be ordered as 4" or 6" machines, but can be altered to easily accommodate the other size by purchasing a hammer and test molds of the desired size. Each machine includes: the mechanical compactor, an automatic counter, tapered-foot hammer assembly for rotating mold models or a flat-foot hammer assembly for the stationary mold models, (1) stability mold, and (1) package of paper discs. Shipping wt. 400 lbs. (181.4kg). Complies with ASTM D6926, D5581, AASHTO T245 and PTM705

Heavy-Duty, Automatic Single Compactor with Rotating Mold

Description	Model
For 4" diameter specimens. 115V 60Hz	H-1364R
For 6" diameter specimens. 115V 60Hz	H-1366R
For 4" diameter specimens. 230V 60Hz	H-1364R.2F
For 6" diameter specimens. 230V 60Hz	H-1366R.2F
For 4" diameter specimens. 230V 50Hz	H-1364R.5F
For 6" diameter specimens. 230V 50Hz	H-1366R.5F

Heavy-Duty, Automatic Single Compactor with Stationary Mold

Description	Model
For 4" diameter specimens. 115V 60Hz	H-1364
For 6" diameter specimens. 115V 60Hz	H-1366
For 4" diameter specimens. 230V 60Hz	H-1364.2F
For 6" diameter specimens. 230V 60Hz	H-1366.2F
For 4" diameter specimens. 230V 50Hz	H-1364.5F
For 6" diameter specimens. 230V 50Hz	H-1366.5F

General Information

Inspection:

Your Marshall Automatic Compaction Machine was thoroughly inspected before it was shipped and should be ready to operate as soon as you have completed the set-up procedure. Notify Humboldt Mfg. Co. or your local agent and file a claim with any carriers involved if you find any damage to the machine.

Physical Specification:

Shipping weight :	400 lbs. (180 kg)
Overall height :	65"
Width & Depth dimension:	24" X 21"
Free fall of hammer:	18"

Power Supply:

110 VAC 60 Hz 1 phase (H-1364/1364R), 300 watts
220 VAC 50 Hz 1 phase (H-1364.5F/1364R.5F), 300 watts
220 VAC 60 Hz 1 phase (H-1364.2F/1364R.2F), 300 watts

Check that your machine has the correct voltage for your local supply.

Fuses:

The Marshall Compaction Machine uses a time-delay fuse, which is fitted into the H-1334 Counter used with the machine. The replacement part number is H-1339.13.

Initial Installation

Remove the packing list and verify that all parts have been received. Normally you will receive one crate, which is a tall box.

Inside the crate you will find the following items: pedestal, compactor, hammer, mold, and counter.

Set the machine & pedestal up at the place it is to be used in the laboratory and then check that it is level by placing a spirit level on the base plate. If it is not level, adjust the floor mounting surface for the machine.

Check adjustment of H-1360 proximity sensor (H-1334A/1334B photo sensor).

From the front, observe the clamping plates clamped by a hand knob to the right side beam. The retro-reflective, infra-red sensor is mounted in front and secured with two nuts, one on each side.

The Sensor is positioned, as shown in the diagram above, with the indicating light facing forward. When the sensor receives a signal from the reflective tape target, the light will flash and send a signal to the counter. It may be necessary to adjust the sensor range if you are experiencing counting problems (missed counts/no counts). To adjust the sensor, use the screw on the back of the sensor to adjust the retroreflective infrared beam to achieve consistent counting actuation is achieved.

When the hammer is lifted and sensed by the photo eye, then dropped out of view, a count is registered. Use of the reflective tape enclosed (see diagram), may be necessary (depending on the hammer finish) to ensure only one transition per drop is registered.

After testing indicates it is necessary to adjust the height of the sensor, position the sensor by loosening the hand knob holding the clamping plates and sliding the assembly into position.

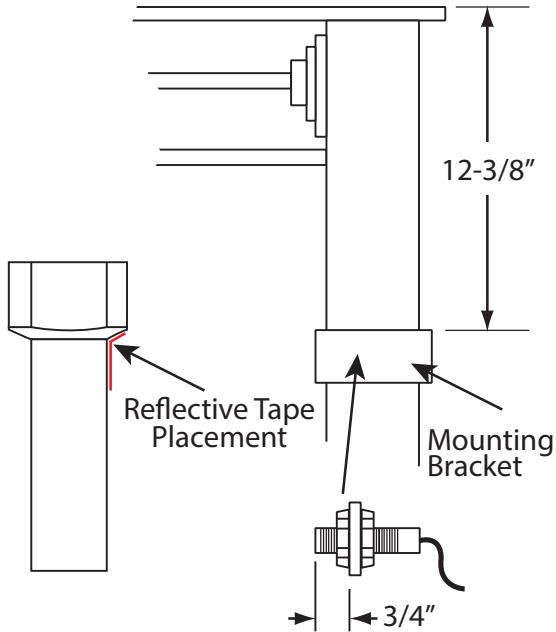

H-1334BA — Installing the Proximity Sensor for your H-1334BA Automatic Counter on a Humboldt H-1364, H-1366 Marshall Compactor.

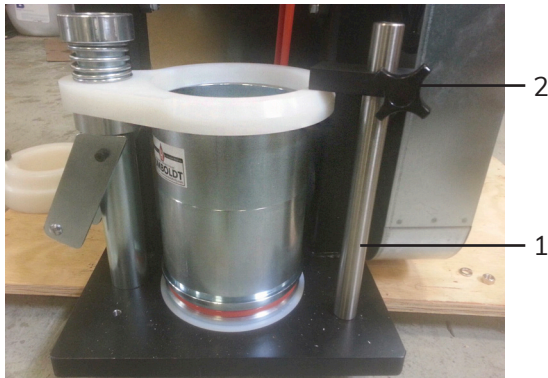

H-1360.35 Auxillary Mold Retainer installation for all model Compactors

1. Thread retainer shaft through hold in base plate and fasten to pedestal with washer and nut provided.
2. Loosen black knob and adjust height of hold down arm
3. Tighten knob.

Operation

Test Specimens

Prepare at least three specimens following procedures outlined in ASTM D1559, D5581, D6926, D6927 and AASHTO T245.

Thoroughly clean the specimen mold, and face of the compaction hammer, heat them according to specification, and introduce the mixture as explained in the standard.

Replace the collar, place the mold assembly on the compaction pedestal in the mold holder, and preset the specified number of blows (to each side of the specimen) using the H-1334 counter's preset switch. Actuate the counter to begin compaction, which will automatically end at the preset number

To make mold removal and reversal easy lift the entire hammer assembly and rotate the top weight $\frac{1}{4}$ turn either way allowing the release wedge to rest on top of the guide support while you load a new mold and sample. After loading the mold rotate the

release wedge to the back and the hammer will be in place to begin compaction. The following figure shows these positions.

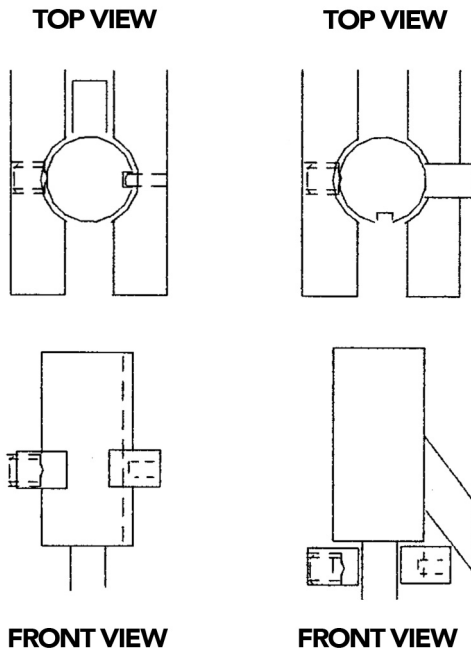

Maintenance

The gearbox is filled with oil and does not normally require further attention. If necessary to add oil use AGMA Grade 8A-EP, SAE 250. Pillow block bearings should be lubricated regularly with multi-purpose or heavy duty grease through the grease fittings provided. Care must be taken to avoid handling the hammer rod(s) with dirty gloves – keep the hammer rods clean. The compactor's exposed, moving metal parts should be kept clean and lightly oiled.

Hammer Assemblies and Replacement Parts



Description	Model
Compaction hammer, 10 lb (for 4" mold)	H-1360A.30
Compaction hammer, 22.5 lb (for 6" mold)	H-1360B.30
Hammer slide shaft	H-1360A.32
Spring retainer, anvil	H-1360A.32.1
Spring washer, anvil	H-1360A.33
Hammer foot, 4" tapered	H-1360A.35
Hammer foot, 4" flat	H-1360AF.35
Hammer foot, 6" tapered	H-1360B.35
Hammer foot, 6" flat	H-1360BF.35
Hammer release pin, left hand	H-1360A.37L
Hammer release pin, right hand	H-1360A.37R



Hammer Assemblies and Replacement Parts

Description	Model
4" hammer with tapered foot (rotating mold)	H-1360A
6" hammer with tapered foot (rotating mold)	H-1360B
4" hammer with flat foot (stationary mold)	H-1360AF
6" hammer with flat foot (stationary mold)	H-1360BF
Lift Chain for H-1364, H-1366 Series	H-1360.21
Replacement pedestal for H-1364 and H-1366 Compactors	H-1347M
Replacement Counter / proximity switch for Compactors	H-1334BA
Replacement Counter / proximity switch for Compactors, 230V	H-1334BA.4F

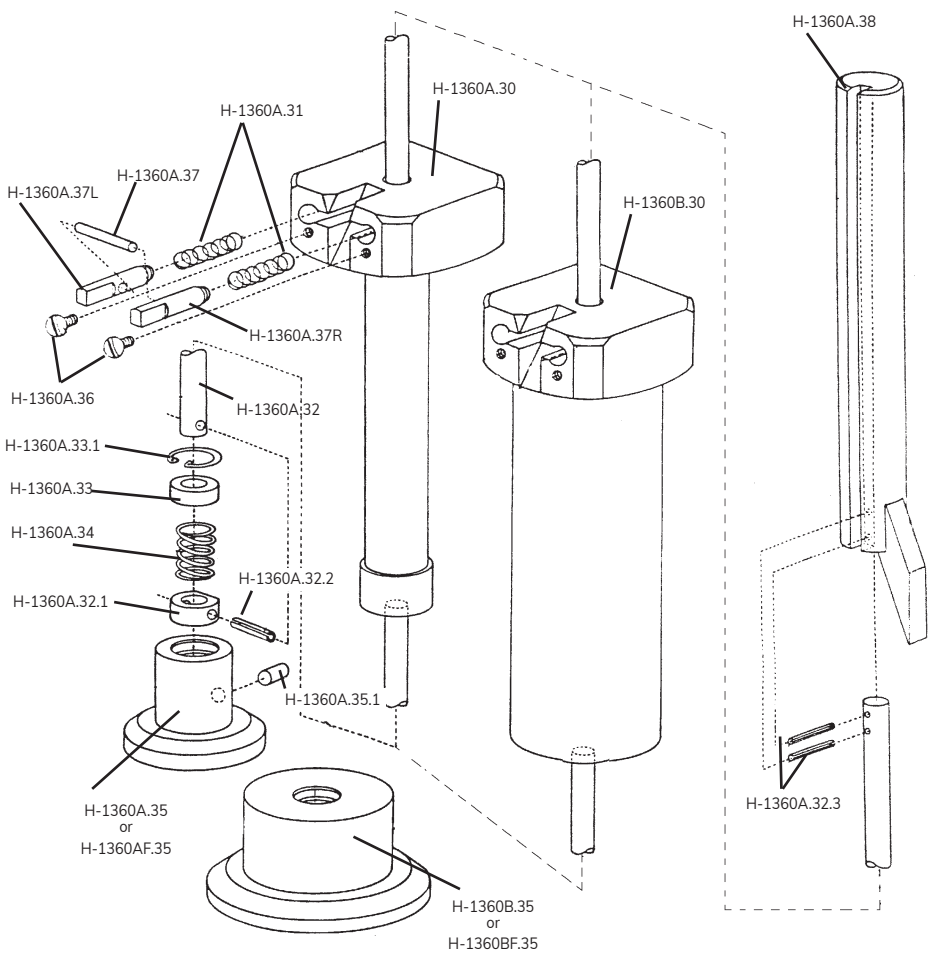

Description	Model
Anvil release arm weldment	H-1360A.38
Hammer release arm	H-1360A.38.1
Anvil, top	H-1360A.38.2
Spring	H-1338.34
Spring	H-1360A.31
1/4" dia. x 1" large roll pin	H-1360A.32.2
3/16" dia. x 1-1/2" roll pin	H-1360A.32.3
Internal retaining ring	H-1360A.33.1
5/16" dia x 1/2" large dowel pin	H-1360A.35.1
1/4-20 x 1/2" large truss head screw	H-1360A.36
1/4" dia. x 1-3/8" Large dowel pin	H-1360A.37

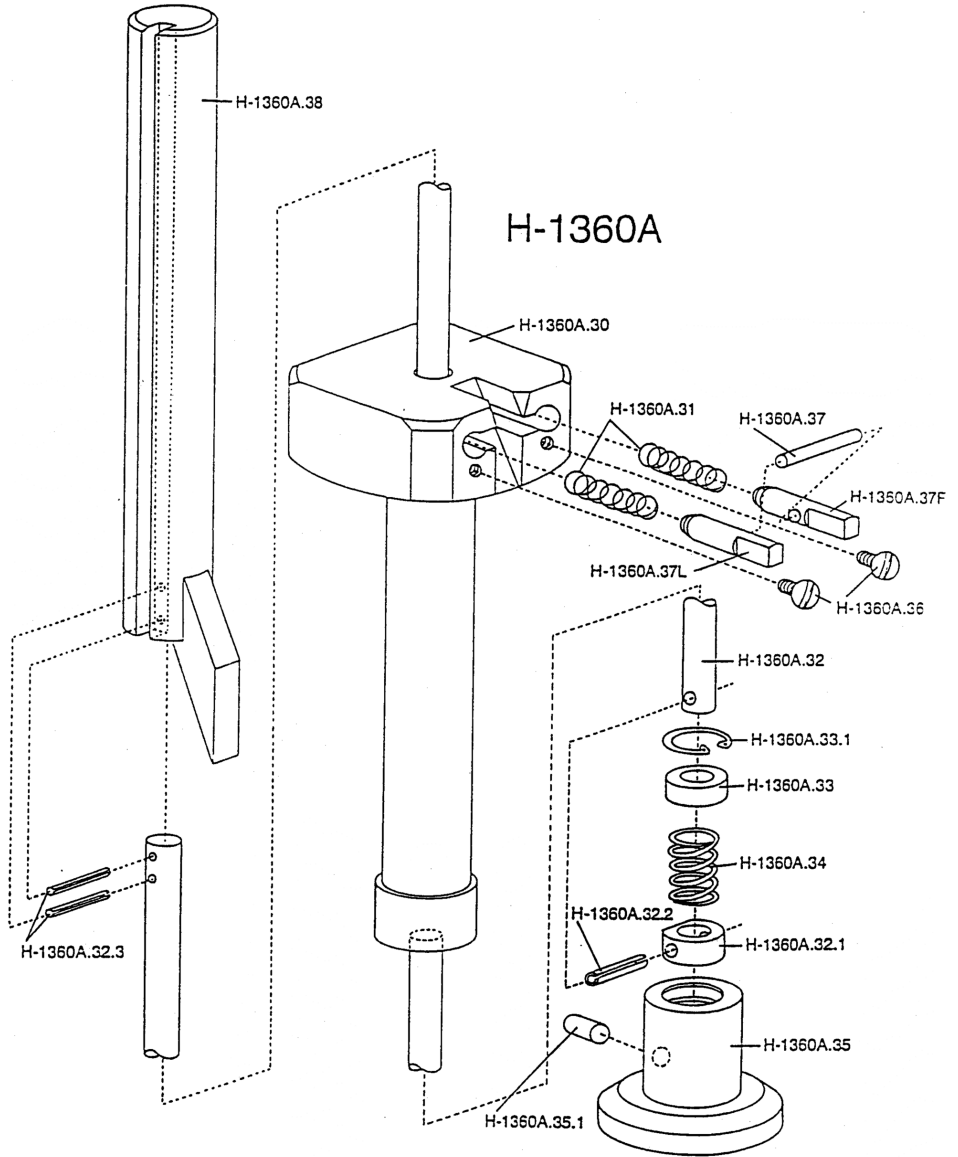

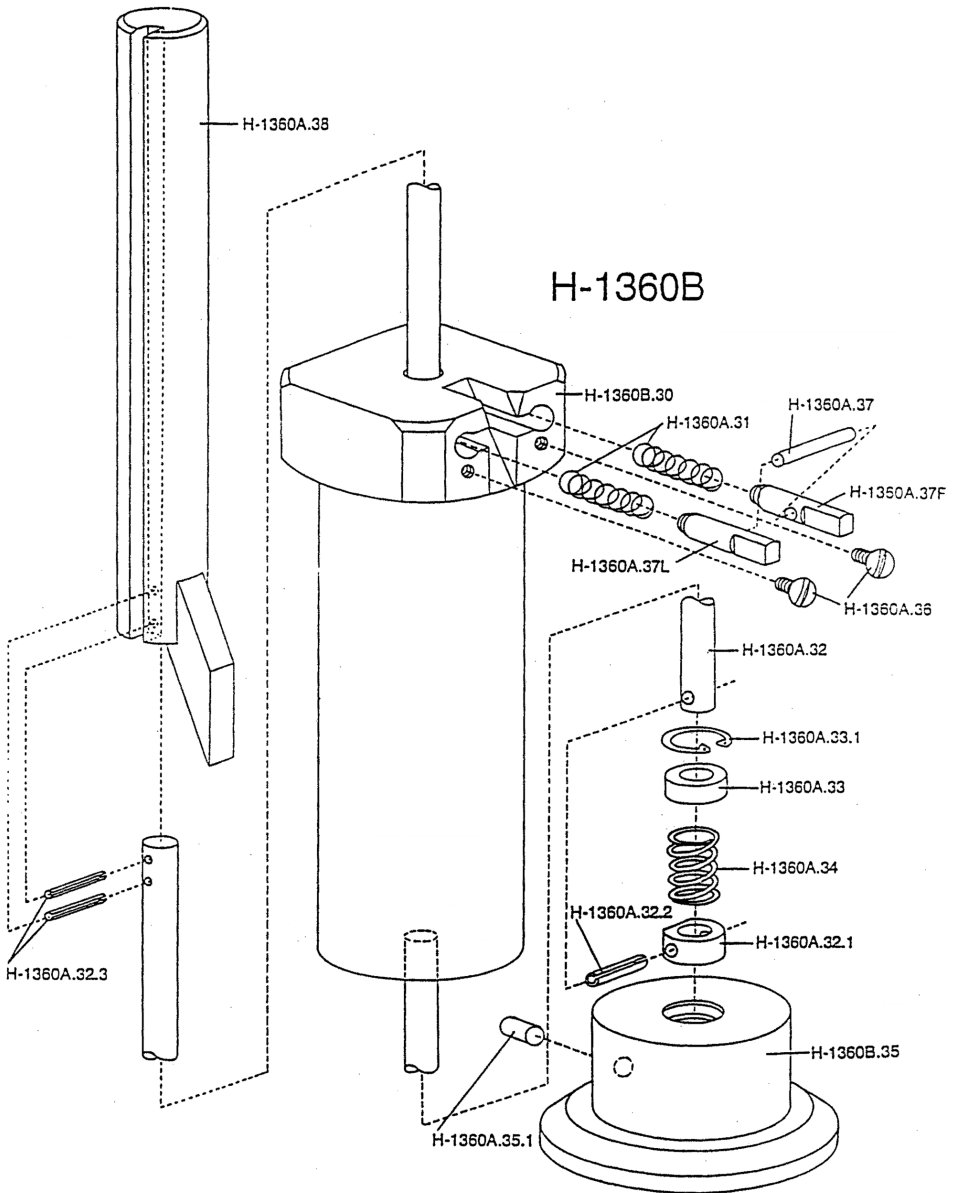

Warranty

Humboldt Mfg. Co. warrants its products to be free from defects in material or workmanship. The exclusive remedy for this warranty is Humboldt Mfg. Co., factory replacement of any part or parts of such product, for the warranty of this product please refer to Humboldt Mfg. Co. catalog on Terms and Conditions of Sale. The purchaser is responsible for the transportation charges. Humboldt Mfg. Co. shall not be responsible under this warranty if the goods have been improperly maintained, installed, operated or the goods have been altered or modified so as to adversely affect the operation, use performance or durability or so as to change their intended use. The Humboldt Mfg. Co. liability under the warranty contained in this clause is limited to the repair or replacement of defective goods and making good, defective workmanship.

Humboldt Mfg. Co.
875 Tollgate Road
Elgin, Illinois 60123 U.S.A.

U.S.A. Toll Free: 1.800.544.7220
Voice: 1.708.468.6300
Fax: 1.708.456.0137
Email: hmc@humboldtmfg.com

Testing Equipment for



Construction Materials

HUMBOLDT

www.humboldtmfg.com