



product manual

H-1750, H-1750SS, H-1751

H-1750_50SS_51_man_1108



Vacuum Pycnometer

Introduction

This Vacuum Pycnometer is used in Rice Testing to determine the maximum specific gravity of bituminous paving mixtures with maximum aggregate size up to 19.1mm (3/4 inch). Designed for operator safety, set includes aluminum volumetric canister, volumetric lid, flat Plexiglas vacuum lid with o-ring, volumeter, release valve and fittings, metal water vacuum aspirator with 3/8" IPT, 6' hose. Unit achieves vacuum using an aspirator or optional vacuum pump. Order H-1756 vibrating table or H-1782 de-airing table and H-1752, H-1754 or H-1754D manometer separately. Replacement parts are available separately. Meets ASTM D2041 & AASHTO T209, T283.

Attach Aspirator to a water supply that will maintain a constant, high flow rate. Attach one end of vacuum hose to Aspirator. Attach the other end of vacuum hose to hose nib on the vacuum lid.

Note: After extended use the Aspirator may lose performance because of solids build up from water.

Operating Instructions

Place vacuum lid on volumetric-check seating of rubber o-ring.

Close release valve.

Turn on water to run through Aspirator-observe direction of vacuum with a vacuum gauge. If the unit seals, the needle on the gage will change reading. Tap gage lightly as the vacuum is drawn. Vacuum is to be minimum of 28 inches, and compliance with the standards requires an absolute pressure manometer.

If a seal is not obtained recheck above procedure and then place light pressure on the vacuum lid with your hands.

Clean Up

To remove vacuum lid-open release valve to allow air and enter the volumeter. Do not try to remove the lid or turn off water while vacuum is drawn on volumeter.

Remove o-ring from vacuum lid. Clean o-ring and wipe its contact surface on vacuum lid and volumeter.

Store in safe place until needed again.

H-1750, H-1750SS & H-1751 Parts List

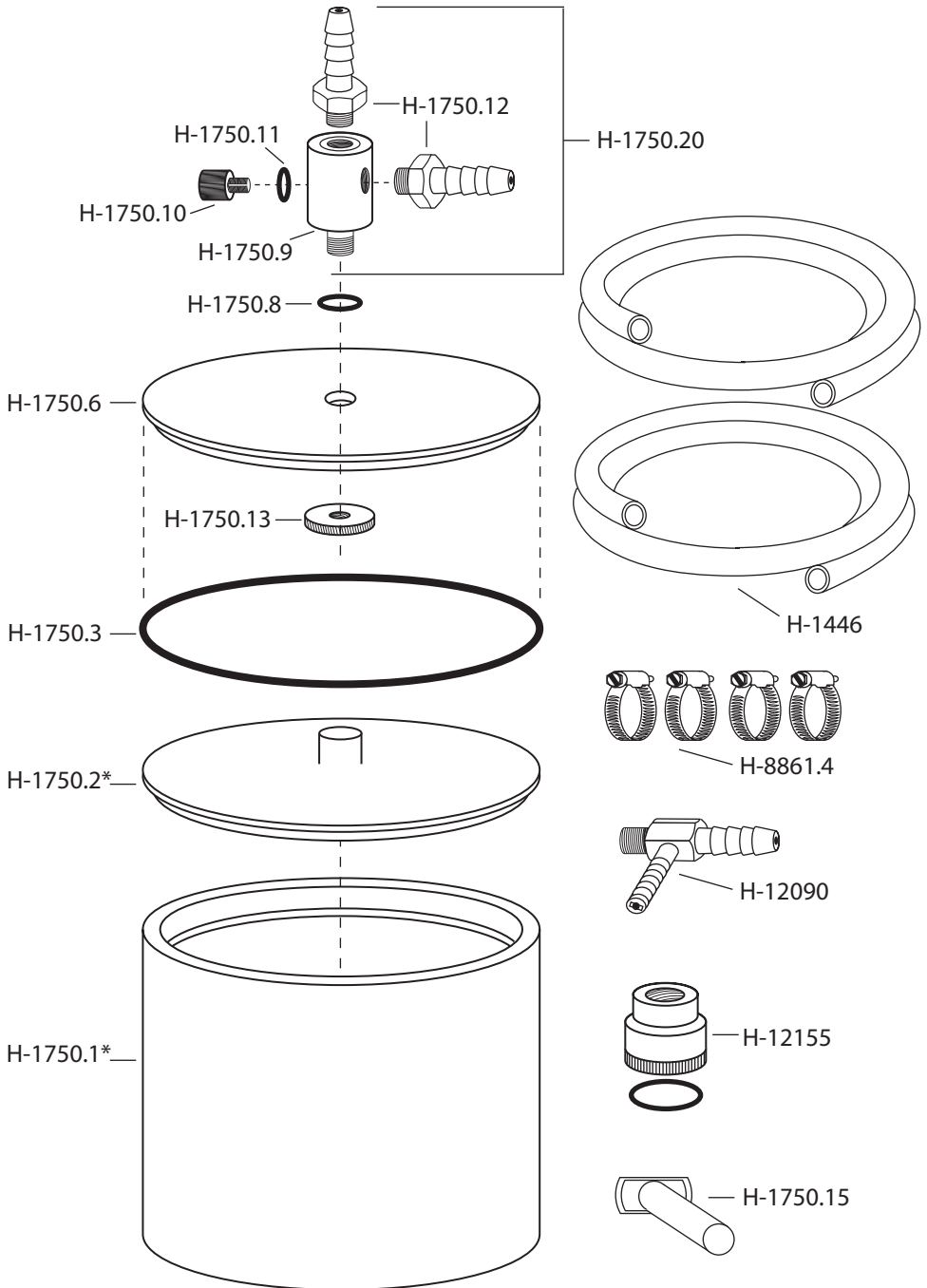

*For Stainless Steel Model, H-1750SS, substitute H-1750SS.1 and H-1750SS.2

* For H-1751, 1500g capacity model, substitute H-1751.1

Warranty

Humboldt Mfg. Co. warrants its products to be free from defects in material or workmanship. The exclusive remedy for this warranty is Humboldt Mfg. Co., factory replacement of any part or parts of such product, for the warranty of this product please refer to Humboldt Mfg. Co. catalog on Terms and Conditions of Sale. The purchaser is responsible for the transportation charges. Humboldt Mfg. Co. shall not be responsible under this warranty if the goods have been improperly maintained, installed, operated or the goods have been altered or modified so as to adversely affect the operation, use performance or durability or so as to change their intended use. The Humboldt Mfg. Co. liability under the warranty contained in this clause is limited to the repair or replacement of defective goods and making good, defective workmanship.

Humboldt Mfg. Co.

875 Tollgate Road
Elgin, Illinois 60123 U.S.A.

U.S.A. Toll Free: 1.800.544.7220

Voice: 1.708.456.6300

Fax: 1.708.456.0137

Email: hmc@humboldtmfg.com

Testing Equipment for



Construction Materials

HUMBOLDT

www.humboldtmfg.com