

Gilmore Apparatus

REMOVE PROTECTIVE TIP GUARDS BEFORE PLACING INTO SERVICE.

IF NECESSARY THE NEEDLES MAY BE SLID UP TO STRIP OFF THE GUARDS.

KEEP TIPS CLEAN AND REFER TO ASTM C266 FOR CONDUCT OF TESTS.

Tip Gaurd Removal:

If unable to remove either tip guard by simply pulling down, remove the 6-32nd set screw in the side of the weight using a 1/16" hex Allen key (wrench) and slide the needle up to strip off the guard.

NEEDLE ASSEMBLY REPLACEMENT: (RECOMMENDED)

- Order H-3151 and/or H-3152 for precalibrated replacement assemblies.
- Remove the 6-32nd set screw in the side of the weight using a 1/16" hex Allen key (wrench).
- Remove the old and install the new needle assembly.

NEEDLE REPLACEMENT AND CALIBRATION: (NOT RECOMMENDED)

- Remove the 6-32nd set screw in the side of the weight.
- Using a 1/16" hex Allen key (wrench).
- Remove the old and install the new needle.
- Calibrate the H-3152 by removing the 10-32nd set screw from the top of the weight using a 3/32" hex Allen wrench.
- Add or remove lead shot to achieve the weight spec of 113.4 ± .5 Grams (.250 ± .001 Lb.)
- Calibrate the H-3151 by removing the ¼-20 set screw from the top of its weight using a 5/32" hex Allen wrench.
- Add or remove lead shot to achieve the weight spec of 453.6 ± .5 Grams (1.000 ± .001 Lb.)
- Install reassembled needle(s) and check for free and unimpeded drop

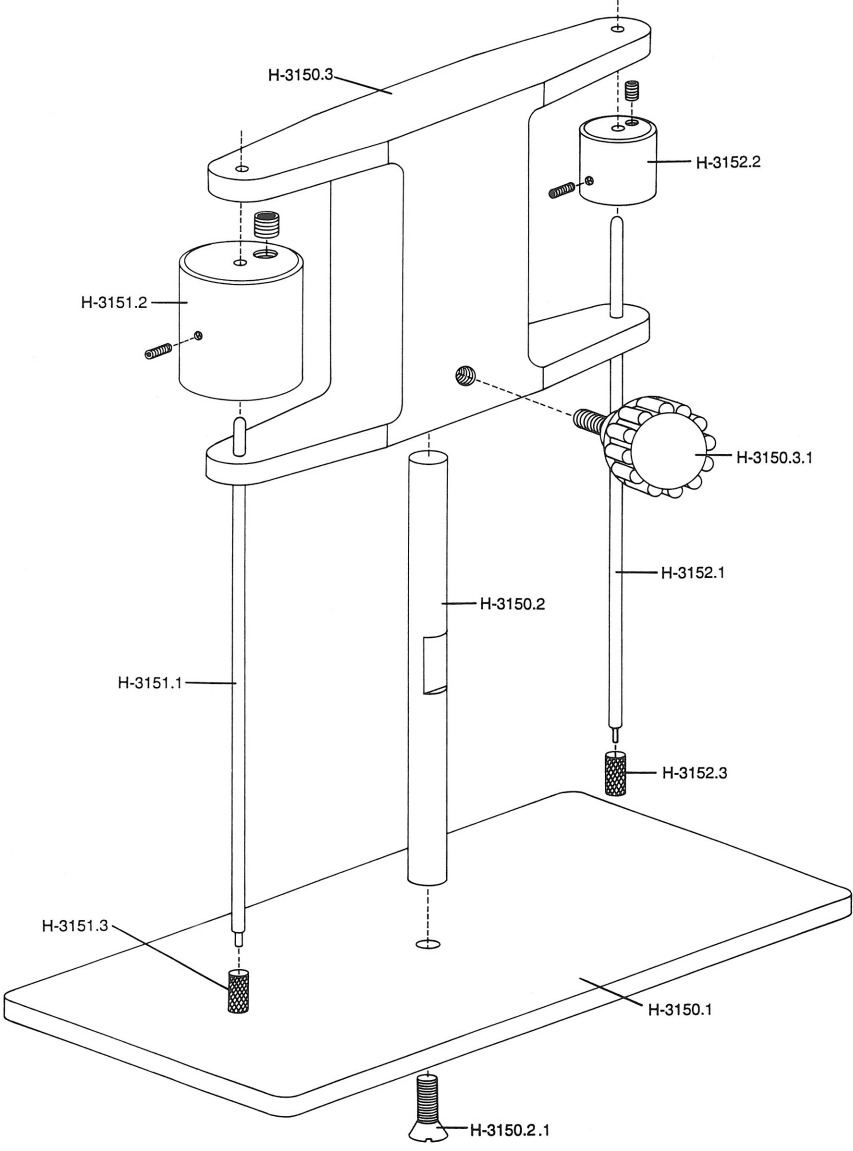

Warranty

Humboldt Mfg. Co. warrants its products to be free from defects in material or workmanship. The exclusive remedy for this warranty is Humboldt Mfg. Co., factory replacement of any part or parts of such product, for the warranty of this product please refer to Humboldt Mfg. Co. catalog on Terms and Conditions of Sale. The purchaser is responsible for the transportation charges. Humboldt Mfg. Co. shall not be responsible under this warranty if the goods have been improperly maintained, installed, operated or the goods have been altered or modified so as to adversely affect the operation, use performance or durability or so as to change their intended use. The Humboldt Mfg. Co. liability under the warranty contained in this clause is limited to the repair or replacement of defective goods and making good, defective workmanship.

Humboldt Mfg. Co.

875 Tollgate Road
Elgin, Illinois 60123 U.S.A.

U.S.A. Toll Free: 1.800.544.7220

Voice: 1.708.468.6300

Fax: 1.708.456.0137

Email: hmc@humboldtmg.com

Testing Equipment for



Construction Materials

HUMBOLDT

www.humboldtmg.com