



Benkelman Beam

General

The H-3220A Benkelman Beam Apparatus is a convenient and accurate device used for measuring the deflection of flexible pavements under moving wheel loads.

Operating on a simple lever arm principal, the device consists of a reference beam body, two-part probe beam, and rear zero adjustment assembly. The dial indicator is not included and must be purchased separately.

The Benkelman Beam has the following key features:

- Lightweight aluminum construction for easy transport to test site locations.
- Telescoping design for easy set up and reduced storage space requirements.
- Easy-reading dial indicators for fast and accurate deflection measurements.
- Built-in vibration system for improved dial indicator accuracy and repeatability.

These operating procedures do not contain all of the required information on the complete test procedures used to measure the deflection of flexible pavements under moving wheel loads. Please refer to the American Association of State Highway and Transportation Officials (AASHTO) test method T256 for more information.

Installation

Assembly and Preliminary Setup

1. Carefully unpack the unit and inspect it for any evident damage. Report any damage or defects to Humboldt's Customer Service Department immediately and save original packaging.

Indicator Installation

The following instructions cover preliminary adjustments of the digital indicator; final adjustments for individual operating techniques and field conditions can be made in the field.

1. Place the Benkelman Beam on a sturdy workbench or table. Loosen the lock nut (Fig. 1, #39) and the stop screw (#34). This stop screw acts as a mechanical stop, preventing the dial indicator from bottoming out when the unit is moved with the beams extended. Later adjust the screw correctly to eliminate the possibility of repeated bottoming, which can cause severe damage to the dial indicator.
2. Deflect the spring clip and extend the center and end beams (Fig. 1, #16 & #22) out about two feet. Remove the locking studs (#15 & #14) from their storage holes and place them aside for later installation. 3. Gently install the indicator into the indicator collet (Fig. 1, #7), loosening the collet nut, if necessary. By placing a finger through the hole on the side of the inner frame beam, move the beam through its extreme up and down range. Watch the indicator as you move it. **(If you are using a dial indicator, count the number of pointer revolutions your dial indicator makes from one extreme to the other, and record this number for future reference.)**

Adjust the stop screw (#34), turning it in a clockwise direction, so the indicator does not bottom out when it's in the up position. This point is reached when the indicator reading does not move while the operator is turning the stop screw.

4. After adjustment, turn the stop screw (Fig. 1, #34) in a clockwise direction, until approximately .004 of movement is registered on the indicator. Now tighten the lock nut against the frame. Recheck the adjustment, making sure the indicator is not bottomed out when the frame beam is moved to the extreme top of its travel. **(When using a dial indicator turn the stop screw (Fig. 1, #34) in a clockwise direction, until approximately two divisions of pointer movement are shown on the dial indicator.)**
5. Turn the thumb wheel (Fig. 1, #45) until the bottom of the leveling screw (Fig. 1, #49) is about 1-½" below the bottom of the frame.
6. Moving the Benkelman Beam to a smooth, hard, level floor, extend the beams to their full length, locking them into position with the locking studs.
7. Note the relative position of the front follower tip (Fig. 1, #18) and the dial indicator pointer. If the front follower tip is not on the floor, loosen the lock nuts (#25) and screw the front leveling feet into their supports until the indicator is about in its mid range. Making sure the two leveling feet are an equal distance from the bottom of the frame, use the lock nuts to lock them in place. The indicator is now in its correct location, protected from bottoming damage.
8. Before carrying the Benkelman Beam with its beam extended, it is suggested that the operator remove the dial indicator from the indicator collet. This practice will prevent any shock movement, prolonging the accuracy and performance of the dial indicator.

Operation

- A. Place the unit 4.5 feet (1.37 m) behind the point of the pavement to be tested. Insert the probe beam between the dual tires of the vehicle, centering it so the tip of the probe rests on the test point.
- B. Turn on the vibrator system and adjust the position of the rear support (Fig. 1, #45) so the dial indicator is set to zero. Lock the rear support in place with its locking screw (Fig. 1, #3). If additional adjustment is necessary, it can be done by repositioning the height of the front legs. Zero the digital indicator or note the dial indicator reading.
- C. Drive the test vehicle forward at the test speed, recording the maximum dial indicator reading as the vehicle advances.
- D. After the vehicle has stopped (approximately 25 feet or 7.62 m in front of the test point), record the final dial indicator reading.
- E. Turn off the vibrator system.

Calculations

The H-3220A series Benkelman Beam has a level ratio of 2:1, the H-3221HA Digital indicator has been calibrated to read the true deflection of the beam probe point, eliminating the need for any conversions. **(For those using dial indicators: Pavement Reading = Maximum Reading minus Final Reading.)**

Indicator Models Available

H-3221HA— Horizontal, Digital Indicator, 1-inch range, .001 accuracy

H-3222— Vertical Dial Indicator, 1/2" range x 0.002" divisions
(travel is 1" on dial)

H-3222M— Vertical Dial Indicator, 14 mm range x 0.02 mm divisions
(travel is 28mm on dial)

Specifications

Main Body:	55" (1397 mm) long, black aluminum finish
Probe Beam:	Aluminum, 8ft. (2.4 m) long, telescopes into case for storage
Probe Fulcrum:	Ball pivot bearing, gives lever ratio of 2:1
Vibrator System:	Operating switch mounted on top of instrument section (requires 4 "D" -size batteries, supplied)
Indicators:	(not included)
Leveling Wheel:	Adjust beams to proper elevation
Open Length:	12ft. (3.7 m) long
Weight:	Net 35lbs. (15.9kg)

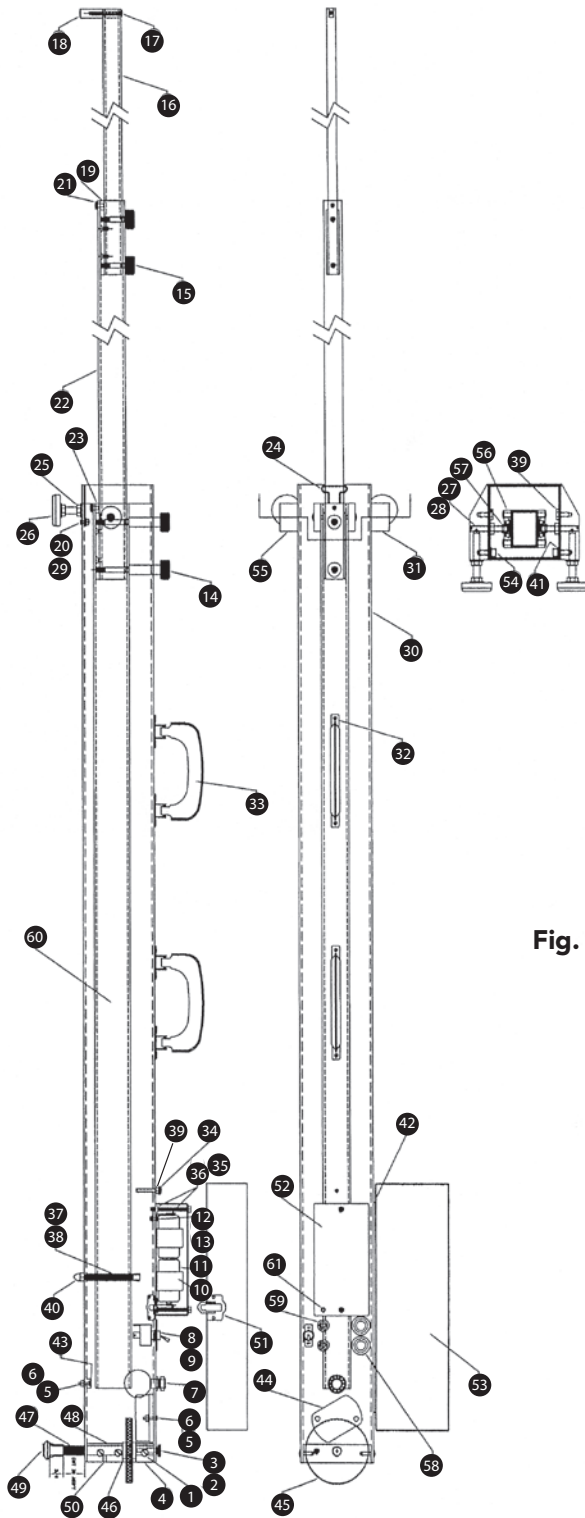

Fig. 1

1	#10-32 x 1/2 Pan HD, Machine Screw	10	41	1/4" Spring Washer	1
2	#10-32 x 1/2 Pan SOC. HD, Cap Screw	1	43	Rubber Bumper	1
3	Thumb Screw Knob	1	44	Buzzer	1
4	Leveling Block – Top	1	45	Thumb Wheel	1
5	#6-32 x 1/2 Binding HD, Machine Screw	9	46	Thrust Bearing	2
6	#6-32 Keps Nut	8	47	Leveling Screw	1
7	Indicator Collet Assembly	1	48	Leveling Block— Bottom	1
8	Switch Logo	1	49	Crutch Tip	1
9	Switch	1	50	#10-32 x 1/2 Set Screw, Dog Point	1
10	Battery Holder	1	51	Snap Latch	2
11	Battery "D" Size	4	52	Battery Box Cover	1
12	#6-32 x 1/4 Binding HD, Machine Screw	12	53	Cover Box	1
13	#6 Internal Tooth Lockwasher	7	54	1/4-20 x 1/2 SOC. HD, Cap Screw	2
14	Beam Locking Studs — Rear	2	55	Front Support, Left	1
15	Beam Locking Studs — Front	2	56	Bearing Housing Assmebly	2
16	End Beam Assembly	1	57	Pivot	2
17	#10-24 x 1-1/4 Binding HD, Machine Screw	1	58	Plastic Grommet— Large	2
18	Follower Tip	1	59	Plastic Grommet— Small	2
19	Stop Block #2	1	60	Frame Beam	1
20	#10-32 x 3/8 Binding HD, Machine Screw	4	61	Plastic Grommet— Small	1
21	#10 Flat Washer	2			
22	Center Beam Assembly	1			
23	Stop Block #1	1			
24	Beam Retainer Spring	1			
25	3/8-16 Hex Nut	2			
26	Leveling Foot	2			
27	5/16-18 Hex Nut	2			
28	5/16-18 x 2 Set Screw Cup Point	2			
29	#10-32 Keps Nut	3			
30	Main Frame	1			
31	Front Support- Right	1			
32	#6-32 x 5/16 Flat Head Screw	8			
33	Handle	1			
34	#10-32 x 1-1/4 Binding HD, Machine Screw	1			
35	Box Cover, Hold Down Rod	2			
36	#8-32 Keps Nut	4			
37	Guide Rod Cover	2			
38	Guide Rod	2			
39	1/4-20 x 1/2 Hex HD. Screw	2			
40	1/4-20 Hex Cap Nut	2			

Warranty

Humboldt Mfg. Co. warrants its products to be free from defects in material or workmanship. The exclusive remedy for this warranty is Humboldt Mfg. Co., factory replacement of any part or parts of such product, for the warranty of this product please refer to Humboldt Mfg. Co. catalog on Terms and Conditions of Sale. The purchaser is responsible for the transportation charges. Humboldt Mfg. Co. shall not be responsible under this warranty if the goods have been improperly maintained, installed, operated or the goods have been altered or modified so as to adversely affect the operation, use performance or durability or so as to change their intended use. The Humboldt Mfg. Co. liability under the warranty contained in this clause is limited to the repair or replacement of defective goods and making good, defective workmanship.

Humboldt Mfg. Co.

875 Tollgate Road
Elgin, Illinois 60123 U.S.A.

U.S.A. Toll Free: 1.800.544.7220

Voice: 1.708.456.6300

Fax: 1.708.456.0137

Email: hmc@humboldtmfg.com

Testing Equipment for



Construction Materials

HUMBOLDT

www.humboldtmfg.com